

CSR/L - G01 Series: High-performance and precision style

Suitable for petrochemical, electric-power, metallurgy, nonferrous metals, light industry and HVAC industry

Unique functions	Power Fail-safe Actuator Position (FL/FC/FO/FS), Substitute configuration, Split-range controlling, DC brushless Motor, Planetary Drive Multi-turn absolute encoder, Hand wheel without clutch
Transducer Sensitivity	0.1%
Actuator Accuracy	≤0.3%
Rotary Output Torque	50 – 1200 Nm
Linear Output Thrust	2 – 48 KN



General Technical Parameters

- Supply Power 24 VDC; 24/110/220/380 VAC (50/60Hz)
- Explosion Protected ATEX IEC Exd IIC T5/T6; Non Ex
- Degree of protection IP66; IP67; IP68
- Ambient Temperature -40 to +80°C
- Input/output Signal
 - Control mode: 4 –20 mA / 0 –10(5)V
 - On/off mode: Dry contact switch
- Communication mode: Mod-bus / M-bus / NB / LOAR / 4G / 5G
- Alarm Way 3 – 6 Ways
- Power Fail-safe Actuator Pos. FL/FC/FO/FS
- Electrical connection 2 – M20x1.5 (Standard)
- Full Stroke time 7 – 300 Seconds
- Rotary output Torque 50 – 1200 Nm
- Linear output Thrust 2 – 48 KN
- Rotary Stroke 90° / Multi-turn
- Linear Stroke 20/40/65/135 mm

Universal design standards

- American society of mechanical engineers (ASME)
- The fire protection association (NFPA)
- National electrical code (NEC)
- The electrical and electronic engineers (IEEE)
- ANSI / IEEE472

Structural Features

- Supply Power: 24 VDC; 24/110/220/380 VAC (50/60Hz).
- High sensitivity and Low system deviation: 0.1% transducer sensitivity, ≤0.3% actuator accuracy.
- Selecting valve position when power fail: FL/FC/FO/Any Position.
- Absolute encoder: The multi gear absolute encoder ensures that the valve position can be reliably detected when the power is off. Even if the handwheel is turned after the power failure, the valve position can be accurately detected and feed back.
- Planetary drive, and Hand wheel without clutch.
- DC brushless Motor, Maintenance free operation, continuous and unlimited regulation.
- Characteristic selecting: Linear/Equal percent/Quick open/Self-definition.
- PID operation of built-in process is optional to realize closed-loop control of process loop.

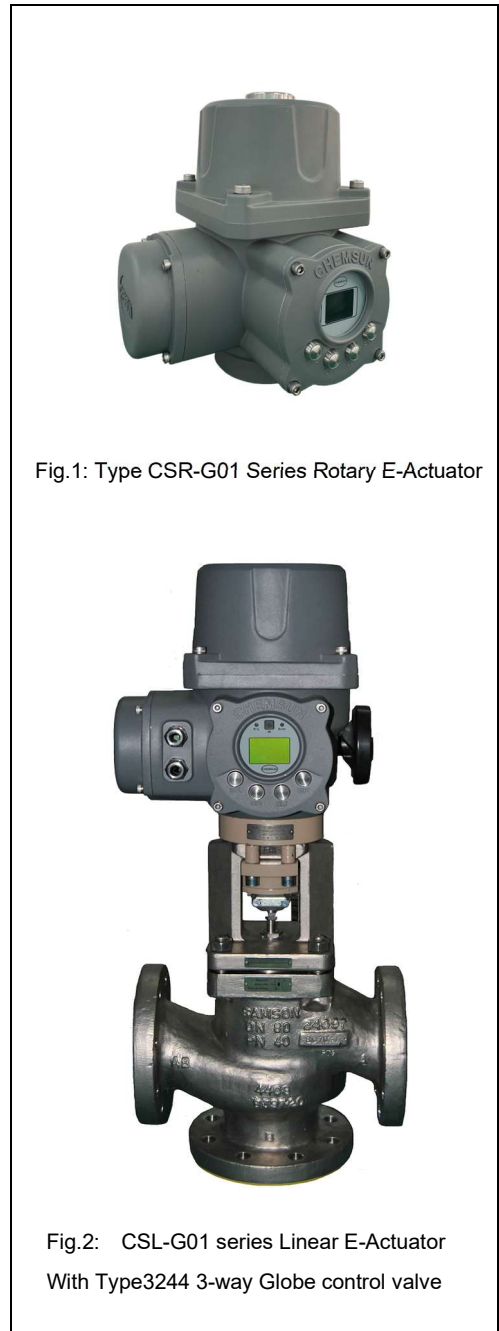

Fig.1: Type CSR-G01 Series Rotary E-Actuator

Fig.2: CSL-G01 series Linear E-Actuator
With Type3244 3-way Globe control valve

- Independent structure of main engine room, configuration warehouse and wiring warehouse, double-sealing.
- The overall explosion-proof design, its type is ATEX Exd IICT5 / T6; the protection grade can reach IP66 / 67 / 68.
- Use Bluetooth or PC for non immersion configuration, calibration and parameter modification.
- Optional HART, FF, Profibus.

Standard Functions

- Non immersion modular design without removing cover: it is unnecessary to open the cover of the main compartment, and complete the parameter setting, initialization, parameter adjustment and modification through the local operation panel button of configuration warehouse, Bluetooth or PC, etc.
- Diversified display functions: input, output, alarm, fault, etc. All menus can be displayed in English, German or Chinese.
- Mechanical transmission features: Planetary gear transmission, smooth operation, small mechanical impact, mechanical life and transmission error far better than worm gear or straight gear transmission structure.
- The control of motor driving mode and running speed: the DC brushless motor is driven by FOC software algorithm. Through PID calculation, the valve position can be slowly opened, fast accelerated close to the set valve position, and then slowly accelerated to the set valve position. The opening and closing time of the regulating valve can be realized by setting or modifying the operating speed.
- The output torque is adjustable: within the maximum rated output torque of the actuator, the output torque that best matches the valve can be set, and the overload protection value can be set within the range of $\pm 0 \sim 100\%$.
- Flow Characteristics Compensation: you can optimize the flow characteristics of the valve, to achieve the best process control quality.
- Stroke limit: two ways to work, mechanical limit and software limit. The mechanical limit is adjusting the stroke switch in the main cabin, to realize the reliable and safe operation of the actuator. The software limit is completed by parameter configuration.
- Local or remote undisturbed switching function: the mechanical design structure without clutch can realize the undisturbed switching between manual and automatic operation.
- Self-diagnosis function: automatic identification and protection for blocking, operation fault, power or signal failure, over current, over temperature, phase sequence, etc. Chemsun operating software can be selected to add diagnosis contents such as valve operation and spare parts replacement prediction.
- Self-inspection and alarm function: fault self-diagnosis and display alarm.
- High positioning precision and frictionless electronic brake technology: when the actuator receives the opening or closing signal, the control unit performs PID calculation to accelerate the running. When approaching the signal position, it slows down the running speed and starts braking to avoid over adjustment or emergency braking, so as to ensure the positioning accuracy.
- The electronic commutation technology is applied to ensure smooth operation and adjustable speed.
- Blocking and overload protection: when the valve is blocked, the valve can not normally reach the valve position of the input signal, and the actuator will automatically try to impact the position for three times. If the automatic impact operation is not successful, the alarm will be given.
- Substitute configuration: It can be replace or repair online. In the production process, if the E-actuator operates fail,

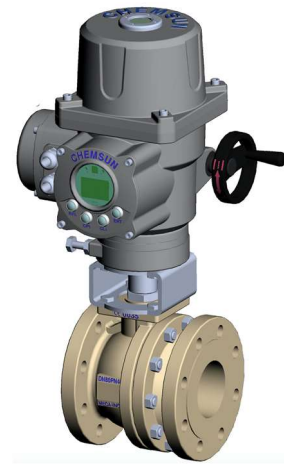

Fig.3: Type CSR-G01 Rotary E-Actuator With CHEMSUN Control V-Ball valve

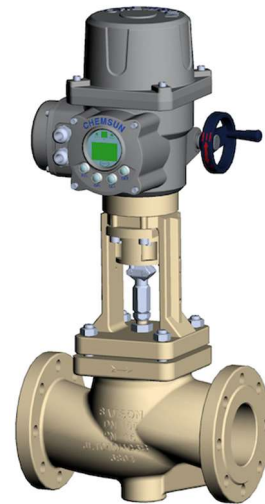

Fig.4: Type CSL-G01 Linear E-Actuator With SAMSON Globe Control valve



Fig.5: Permanent magnet BLDC motor

the sub initialization mode can replace or repair the control boards without shutdown. The Substitute configuration function ensures that the plant continues to operate with this valve position.

- Split-range controlling: One way control signal (such as 4-20mA) output by the controller can control two or more electric valves (connected in series) .

Permanent magnet BLDC Motor

Motor is an important part of electric actuator. The application of Brushless DC motor in electric actuator has brought a great leap to drive control technology.

Permanent magnet brushless DC motor is composed of main body and driver. The motor is a typical mechatronics product. The rotor of the motor is composed of Nd-Fe-B and other rare-earth permanent magnetic alloy materials. Position sensors are installed in the motor to detect the polarity of the electric rotor. The driver composed of integrated circuits and electronic devices controls the start, stop, speed change, forward and reverse rotation of the motor, and provides protection and display.

Brush and brushless Motor technical analysis

Brush motor adopts mechanical commutation, short life, high noise, electric spark and low efficiency. When it is used for a long time, the carbon brush is seriously worn and easy to be damaged. In addition, a large amount of carbon dust is produced by the wear of carbon brush, which causes the bearing oil to dry up quickly and the motor noise increases further. If the brush motor is used continuously for a certain period of time, it is necessary to replace the carbon brush in the motor.

Brushless motor replaces mechanical commutation with electronic commutation, which has no mechanical friction, no wear, no electric spark, no maintenance and can be more sealed, so it is better than the brush motor in technology. Brushless DC motor (BLDCM) has a permanent magnet composed of rare earth materials, such as NdFeB. Its volume is one grade smaller than that of brushless motor or three-phase asynchronous motor with the same capacity.

Permanent magnet BLDC Motor Advantages

- High speed and wide adjustment range, uniform and stable controllable speed, suitable for steady speed, speed regulation, and precision positioning.
- The operation of the motor adopts PID control technology to realize the positive acceleration to steady state and the negative acceleration to stop at the control position. (see Fig. 6b: Analysis chart of working speed and actuator output process of BLDCM).
- It adopts electronic commutation technology, with long service life, high operation reliability, high controllable precision, allowable locked rotor and maintenance free.
- The speed regulation ratio of the motor under constant torque load can reach 1:50~100, which is incomparable with other types of motor.
- The motor has large starting torque, small current, strong overload capacity, good dynamic performance and low calorific value, which is very suitable for long-term continuous operation.
- The operation of the motor does not interfere with the power grid, control system and other electrical equipment, with low power consumption, energy saving and environmental protection.
- It has excellent temperature resistance.

BLDC motor speed and actuator output process analysis

Figure 6a: The relationship between the given current and the position feedback current.

Figure 6b: Analysis chart of working speed and actuator output process of BLDCM.

T1: When there is a deviation between the given signal and the position feedback signal, the motor starts at low speed and accelerates uniformly.

T2: The motor speed gradually increases to the maximum value, and the high constant speed operation is close to the set position.

T3: The deviation decreases and the motor begins to decelerate.

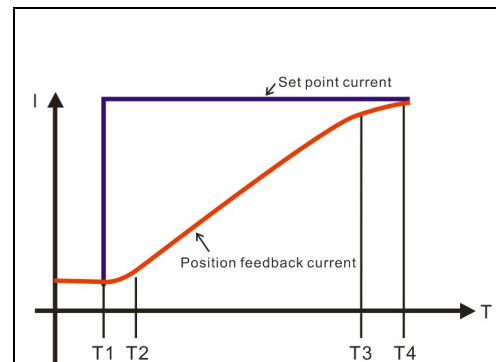

Fig.6a The relation graph between the set current and position feedback current

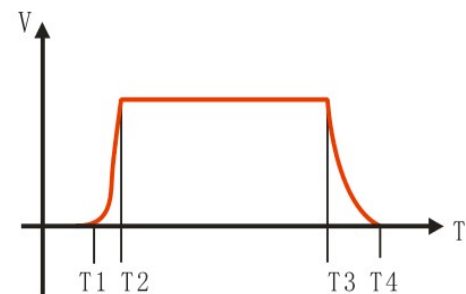

Fig.6b: Analysis chart of working speed and actuator output process of BLDCM

T4: The deviation is eliminated, then the motor stops running.

Internal structure of electric actuator (Fig.7)

1. Bearing
2. Pot gear
3. Bearing
4. Planetary gear assembly
5. Center feedback lever
6. Gear ring
7. Handwheel washer
8. Handwheel
9. Wheel cover
10. Spring groups
11. Spring washers
12. Handwheel worm
13. Motor gear
14. Bearing
15. Center wheel assembly

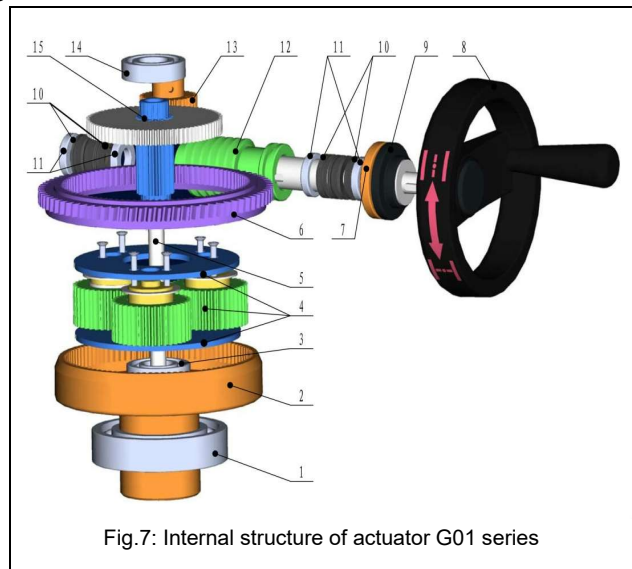

Fig.7: Internal structure of actuator G01 series

Mechanical transmission characteristics

- Planetary gear drive mode

Design Principle

The transmission system of CHEMSUN electric actuator consists of gear ring, pot gear and planetary gears. The inner teeth of ring gear and pot gear are meshed with planetary gears to realize mechanical transmission.

The inner gear of ring gear is meshed with the inner gear of pot gear, and the diameter of graduation circle of them is the same. The tooth number difference can be realized by displacement machining. This structure can not only effectively drive and enlarge the torque, but also reduce the transmission return difference and increase the transmission efficiency.

The outer teeth of the ring gear and the hand wheel worm are worm gear worm structure with self-locking function, and this structure can realize the undisturbed smooth switching between manual and automatic working states without clutch.

*** This kind of transmission structure is Chemsun "utility model patent" applied in the electric actuator.

Advantages of planetary gear system

- The transmission ratio is large, the transmission efficiency is high, and the system error is small.
- Smooth running, low noise, large capacity.
- Long service life.
- Hand wheel without clutch.

Detection and feedback of valve position

The multi gear absolute encoder ensures that the valve position can be reliably detected when the power is off. Even if the handwheel is turned after the power failure, the valve position can be accurately detected and feed back.

The encoder is composed of at least three Hall chips and detection gears, which measure the rotation angle of their own gears. In the case of normally power supply, the absolute angle and the number of running turns are detected by the main gear and its Hall chip, and the signal is transmitted to the CPU of the main control board, which is converted into the valve position data. In the case of power

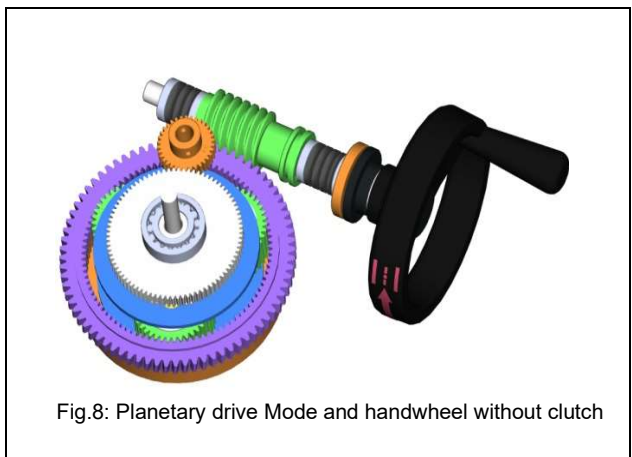

Fig.8: Planetary drive Mode and handwheel without clutch

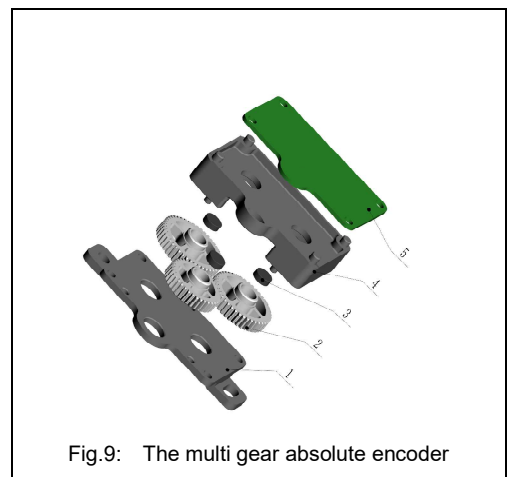

Fig.9: The multi gear absolute encoder

failure, the encoder's main gear and three driven gears have absolute angle difference due to the different number of teeth. The current position data of the valve can be calculated effectively through the specific software algorithm based on the difference between the two angles. And the encoder redundancy design, even if there is a gear or hall fault, it can also ensure the correct detection of valve position.

The absolute hall encoder has a very high detection accuracy of valve position, which can reach 1 / 10000.

Powerful fault diagnosis and protection function

- **Diagnosis and protection of input control signal failure:** it can automatically identify the fault of input signal, including line drop, short circuit, signal beyond normal range, etc. It can send out and display alarm immediately when the fault occurs, and can automatically run to the designated position according to the user's selected signal fault processing mode (full open, full close, hold, any position) .
- **Diagnosis and protection of position feedback signal failure:** automatic judgment of position sensor fault. Once the fault occurs, it outputs the diagnostic alarm signal to avoid miss-operation due to the fault of detection signal.
- **Torque detection and over torque protection:** accurate measurement of actuator output torque through torque sensor is the basis and guarantee for torque protection. At the same time, double detection technology is used to analyze and calculate the measured values of working current and voltage to ensure accurate setting of torque and torque limit and protection. When the actuator is initializing, the over force protection is set. Once the torque is over, the control circuit will stop the motor immediately and send out and display alarm to ensure that the actuator and the driven object are not damaged by excessive torque.
- **Motor over-current and over temperature protection:** Although the starting current and working current of BLDC motor are much smaller than that of AC motor, CHEMSUN has set protection for possible over-current of DC motor and configured with output alarm signal. The temperature sensor is built into the motor to monitor the temperature and temperature rise of the motor anytime. In case of over temperature or abnormal temperature rise, an alarm will be sent and displayed immediately, and the motor power supply will be cut off. When the temperature drops to the set value, the motor will automatically resume normal operation.
- **Automatic blockage removal function:** when the valve is stuck or other mechanical fault causes, the valve to stop moving, the actuator will automatically try three impact actions according to the setting. In case of jam, the control unit instructs the motor to rotate in reverse direction for a small step, and then operate in the original direction. Each impact torque does not exceed the torque protection value, so it is repeated three times. If the jam disappears, the actuator will return to normal operation; if the jam still exists, the motor power will be shut off automatically, and an alarm will be sent out and displayed.
- **Emergency situation handling (ESD) function:** in case of emergency, under the intervention of ESD command, the actuator can directly run to the set position: full open, close, hold or set to any position.
- **Dual protection of valve position limit:** (1) software protection: the upper and lower valve position limits are set through the panel configuration, and the alarm, jump action and motor power cut-off are output when the position is over. (2) Hardware protection: when the upper and lower valve position reaches the limit, the contact switch will interlock alarm, jump action, cut off the motor power supply, etc.
- **Operation of handwheel mechanism:** CHEMSUN adopts differential planetary gear transmission structure, and the handwheel can realize manual operation directly without clutch switching, which completely solves the hidden trouble caused by manual and automatic switching. Automatic is always the priority. When automatic, the handwheel mechanism always keeps static. Even if the handwheel is turned, it will immediately return to the position of automatic signal, which will not cause negative impact. Customers can choose the handwheel locking mechanism.



Fig.10: The super capacitor



Fig. 11: Actuator master control board and interface board

Power Fail-safe Actuator Position

Super capacitor is used to store electric energy. After power failure, the actuator automatically switches to capacitor discharge power supply to ensure that the valve can operate for at least 1.5 strokes. The valve fault safety position can be set as full close, full open, hold or any set position (FC/FO/FL/FS).

Advantages

- It can completely replace the failure reset function of pneumatic control valve realized by spring.
- There is no spring and no mechanical wear.
- The super capacitor adopts aerospace technology and has a service life of more than 20 years.
- It can effectively diagnose whether the power supply is flashing off (0~10 seconds can be selected).
- The charging time is short, and the effective charging can be completed within five minutes.
- Environmental protection and energy saving, no leakage and no pollution.

*** This kind of the function design is Chemsun "utility model patent" applied in the electric actuator.

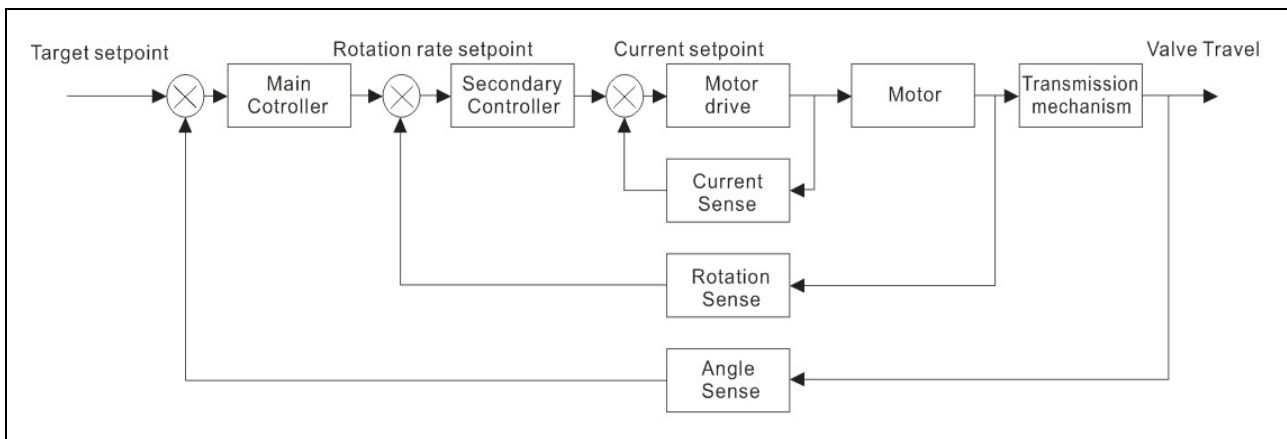

Control principle and main control module

Three stage cascade PID control: drive motor control circuit + motor operation control circuit + final position output control circuit. Customers can adjust the parameters of each control loop according to the site process and working condition requirements, so as to achieve the optimal control quality and control accuracy.

Note: Due to the mutual coupling of each loop of cascade control, the change and adjustment of PID coefficient must be completed under the guidance of professionals or manufacturers.

Independent power supply module

The power supply can be selected 24 VDC or 24VAC, 220VAC, 110VAC or 380VAC. The independent power module converts all kinds of input power into three isolated power supply for motor drive, chip operation and LCD display. It provides a strong guarantee for the reliable operation of various components, and greatly improves the anti-interference ability of the equipment.

Alarm settings

Generally, there are three groups, and at most six groups of alarm outputs can be selected. Each output is a normally open / closed dry node. The alarm content can be configured arbitrarily, and the alarm common terminal is independent, which is suitable for connecting different alarm power supplies.



Fig.12: Independent power supply module



Fig.13: G01Series Operation panel

Control signals types

- Valve position control: According to the control signal (4 – 20mA or 0 – 10V, etc.) output by the controller, PLC or DCS, the actuator automatically and accurately runs to the corresponding valve position.
- Emergency control of ESD: In case of emergency and abnormal conditions, the actuator shall perform actions according to the settings (open, close or other positions) to meet the safety requirements of on-site process.
- On/off control: the actuator implements corresponding switch action according to the input switch signal, and the switch signal can be defined as inching or automatic holding type.
- Various communication modes can be selected: Mod bus, M-BUS, Nb, Loar, 4G and other optional control modes.

Simple and humanized operation

- Configuration button: The four operation buttons on the panel can complete all parameter setting, configuration and adjustment, and check fault information and diagnosis reasons. The information is directly displayed on the screen as intuitive text. English / German / Chinese can be switched freely.
- Optional infrared remote control: the infrared remote controller can replace all functions of panel buttons within 10 meters to set and configure parameters.
- Setting of PC terminal: wireless connection with PC terminal via Bluetooth, setting and configuration of actuator parameters.

HART and Bus communication technology

HART Communication protocol

HART (highway addressable remote transmitter) protocol uses FSK signal based on Bell202 standard, superimposes frequency digital signal on low frequency 4-20mA analog signal for bidirectional digital communication, and the data transmission rate is 1.2 kbps. Because the average value of FSK signal is 0, it does not affect the analog signal transmitted to the control system, which ensures the compatibility with the existing analog system. In HART protocol communication, the main variables and control information are transmitted by 4-20mA. When necessary, other measurement, process parameters, equipment configuration, calibration and diagnosis information are accessed through HART protocol.

CHEMSUN products conform to HART communication protocol, which can easily access any network system conforming to this protocol and provide reliable data transmission.

PROFIBUS DP

PROFIBUS-DP (Decentralized Peripheral) is suitable for the communication between centralized control system and distributed I/O. The master station communicates with distributed field devices (remote I/O, actuator, valve, intelligent sensor or lower layer network) through standard PROFIBUS-DP special cable to manage and control the whole DP network. In PROFIBUS-DP, most of the data exchange is periodic. The first kind of Master gets the input information of each Slave recurrently and sends the relevant output information to them. PROFIBUS-DP can replace 24VDC or 4-20mA signal transmission.

The high-speed data transmission domain layer of PROFIBUS-DP bus is composed of central controller, programmable controller and upper computer. It has a high-speed serial interface, and peripheral devices communicate with binary or analog input and output. It is a room of periodic data exchange equipment. All products with PROFIBUS interface support V1 service function to realize aperiodic data exchange.

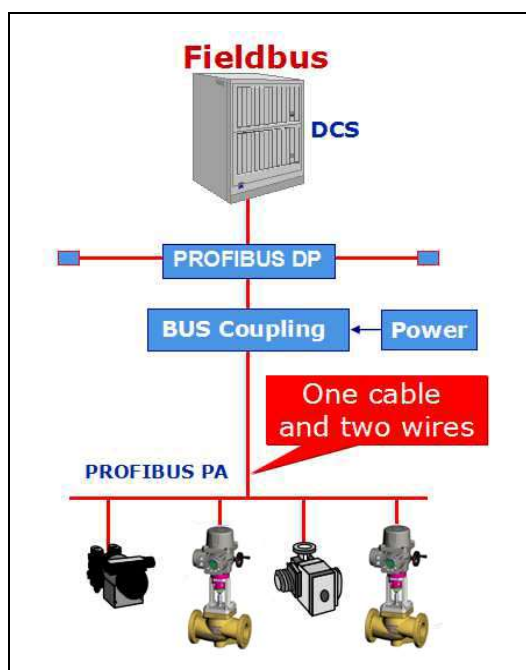
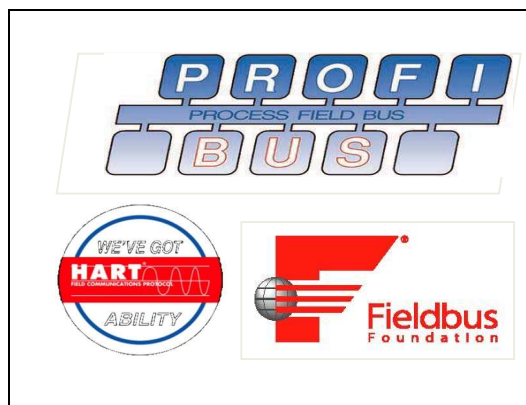

The master station inputs information to the slave station regularly, and receives the output information from the slave station regularly. In addition to processing image periodic transmission, PROFIBUS-DP has powerful diagnosis and debugging functions. At the same time, the master station and the slave station have the monitoring function for monitoring data transmission.

When PROFIBUS-DP communication interface is used, the corresponding GSD file station must be loaded. The GSD file provided by our company contains the file structure, content, code standard, parameter configuration and other related contents. Customers can use these files. The PROFIBUS-DP bus device has its own identification number.

CHENSUN series actuators can be easily integrated into any Profibus fieldbus control system. Fieldbus components can not only pass the certification and test of PROFIBUS user organization (PNO), but also be equipped with other bus interfaces, which are compatible with other bus technologies.

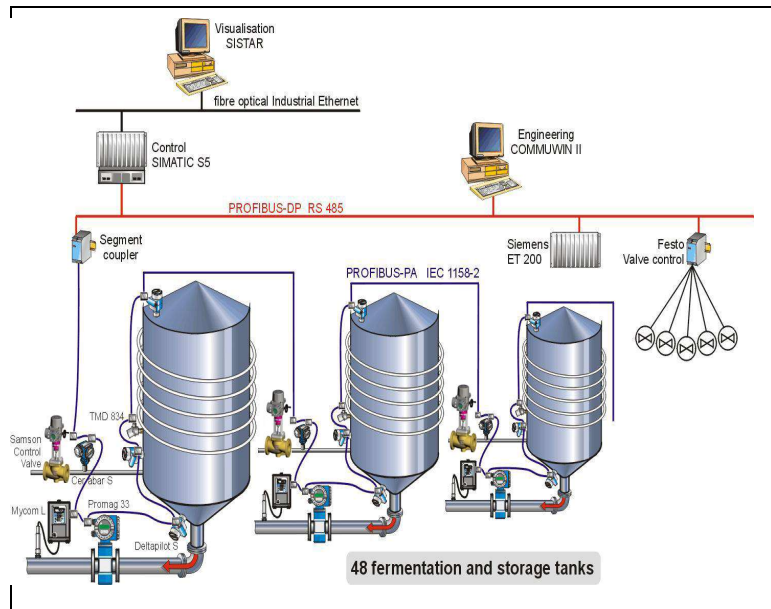

Advantages

- Save hardware cost.
- It is easy to design, configure, install and debug.
- The safety and reliability of the system is good, and the downtime is reduced.
- It is convenient for system maintenance, equipment replacement and system expansion.
- The user's system configuration and equipment selection have maximum autonomy.
- It provides the basis for improving enterprise information system and realizing enterprise integrated automation.

MODBUS RTU

Modbus RTU code is a communication protocol first advocated by MODICOM. After the practical application of most companies, it is gradually recognized as a standard communication protocol. At present, this protocol is widely used in the process of RS232 / RS485 communication. Modbus ASCII protocol and Modbus RTU protocol are commonly used. Modbus RTU protocol is adopted when the communication data is large and binary.

Modbus communication protocol is a general language used in controller. Through this protocol, the controller can communicate with other devices through the network (such as Ethernet). It has become a universal industrial standard. With it, different manufacturers of control equipment can be connected to the industrial network, centralized monitoring.

CHENSUN products conform to the standard Modbus communication protocol, which can easily access any network system in accordance with this protocol. According to the command, after simple parameter configuration, it can provide reliable data transmission.

Product database

Perfect product information management is not only the key link of CHENSUN product quality tracking, but also the important means and guarantee of product quality management. Every product and accessory is recorded in a central database. All product information related to production, processing, assembly, debugging and sales can be traced back to the original data. The maintenance of products can be fed back to the central database through the operation of remote consultation system (PDA), without losing any information, so as to realize the traceability management of product quality.

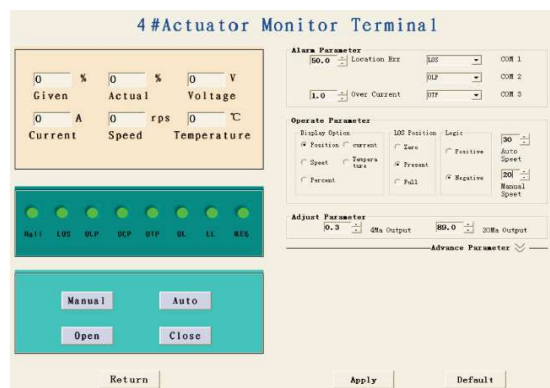
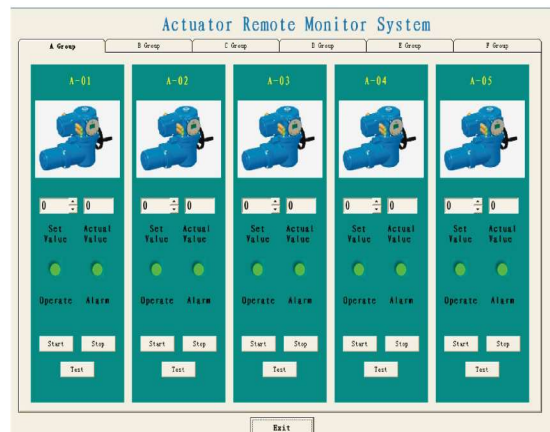

Table 1: Technical data

CHEMSUN CSR/L - G01 Series High-performance and precision adjustment E-Actuators	
Rotary stroke output torque range	50 – 1200 Nm
Linear stroke output thrust range	2 – 48 KN
Stroke range	R: 90° / Multi-turn ; L: 20/40/65/135mm
Supply power	24VDC , 24/220/110/380 VAC (50/60 Hz)
Shell material	Cast Al. 3.2373
Explosion-proof type	ATEX Ex d II CT5/T6 ; Non Ex
Protection grade	IP66 / 67 / 68
Input signal	4 – 20mA; 0 – 10(5)V; On-off Switch; Mod-bus; M-bus; NB; LOAR; 4G
Output signal	4 – 20mA; 0 – 10(5)V; On-off Switch; Mod-bus; M-bus; NB; LOAR; 4G
Power fail safe position	FL / FC / FO / FS
Ambient temperature	Standard -25 to +80°C ; Low temp. -40 to +70°C
Transducer Sensitivity	0.1 %
Actuator Accuracy	≤ 0.3 %
Response time	200 ms
Alarm configuration	3 – 6 Paths
Communication protocol	HART, PROFIBUS, MODBUS
Ambient humidity	100% RH
Adjusting speed range	15 – 100%
Torque adjustment range	10 – 100%
Seismic capacity	3 axis 6 g

Table 2: Basic parameters

CHEMSUN CSR / L - G01 Series High-performance and precision adjustment E-Actuators		
Sell material	Cast Al. 3.2373	
Motor Data	Type	Permanent magnet BLDC motor
	Body material	Cast Al. 3.2373
	Rated power	0.12 KW
	Rotation rate	600 – 4000 rpm Adjustable
	Cooling mode	Air cooling
	Temp. class	About 70°C
	Protection grade	IP 67 / IP68
	Structural chara.	Electronic commutation, drive control motor action
	Insulation grade	Class H
	Moment of inertia	60 g·cm ²
Mechanical drive	Planetary gear transmission	
Hand wheel	Standard, Non-Clutch handwheel	
Position feedback	Absolute encoder	

CSR / L - G01 Series E-Actuators Dimension drawing

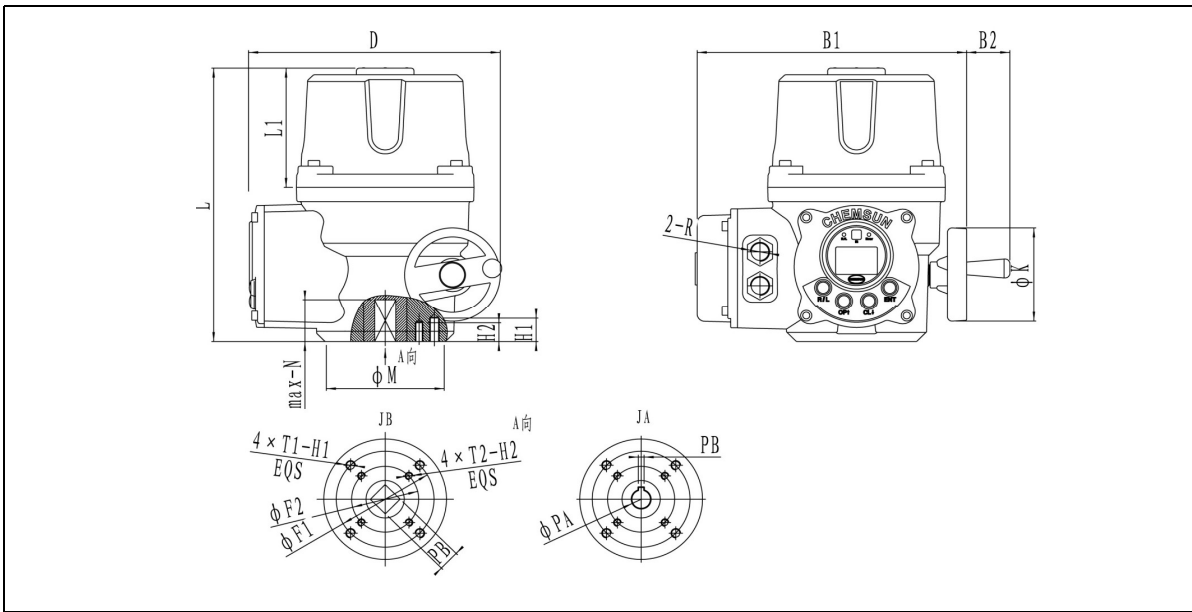

CSR/L-G01 Series E-Actuator main dimension and Flange connection drawing

Unit: mm

Type	PA	PB	F1	F2	T1	T2	H1	H2	Flange size
JA	20	6	102	70	M10	M8	25	20	F07/F10
JB	—	17	102	70	M10	M8	25	20	F07/F10

Type	L	L1	M	B1	B2	N	D	K	R	Weight
G01	285	126	128	281	45	45	257	100	M20x1.5	13.5 Kgs

Note: Standard for JB type, if the user has special needs, Type JA can be equipped. Flange standard according to DIN ISO 5211.

Quarter-turn gearbox dimensions:

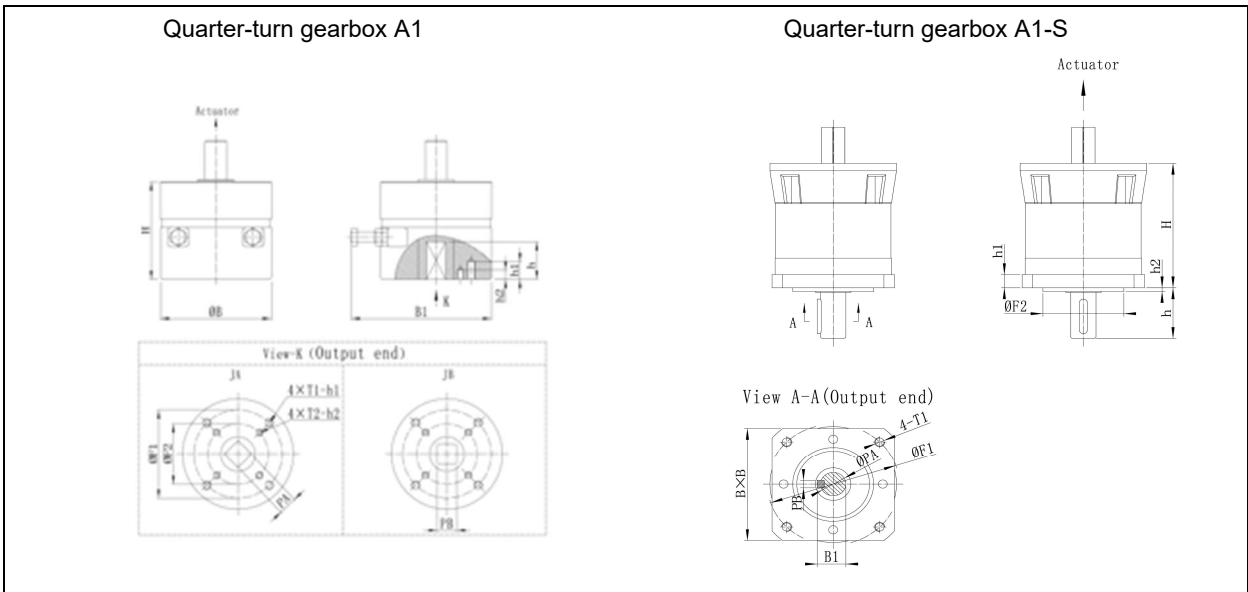

Main dimension

Unit: mm

Type	H	B	B1	PA	PB	h	h1	h2	T1	T2	F1	F2	Flange size	Weight
A1	113	128	165	22	22	35	25	20	M10	M8	102	70	F07/F10	4.5 Kgs
A1-S	128	154	175	27	27	46	30	25	M12	M10	125	102	F10/F12	5.5 Kgs

Note: Flange standard according to DIN ISO 5211.

CSL-G01 Series Linear E-Actuators (With SAMSON type 3241 Globe control valve)

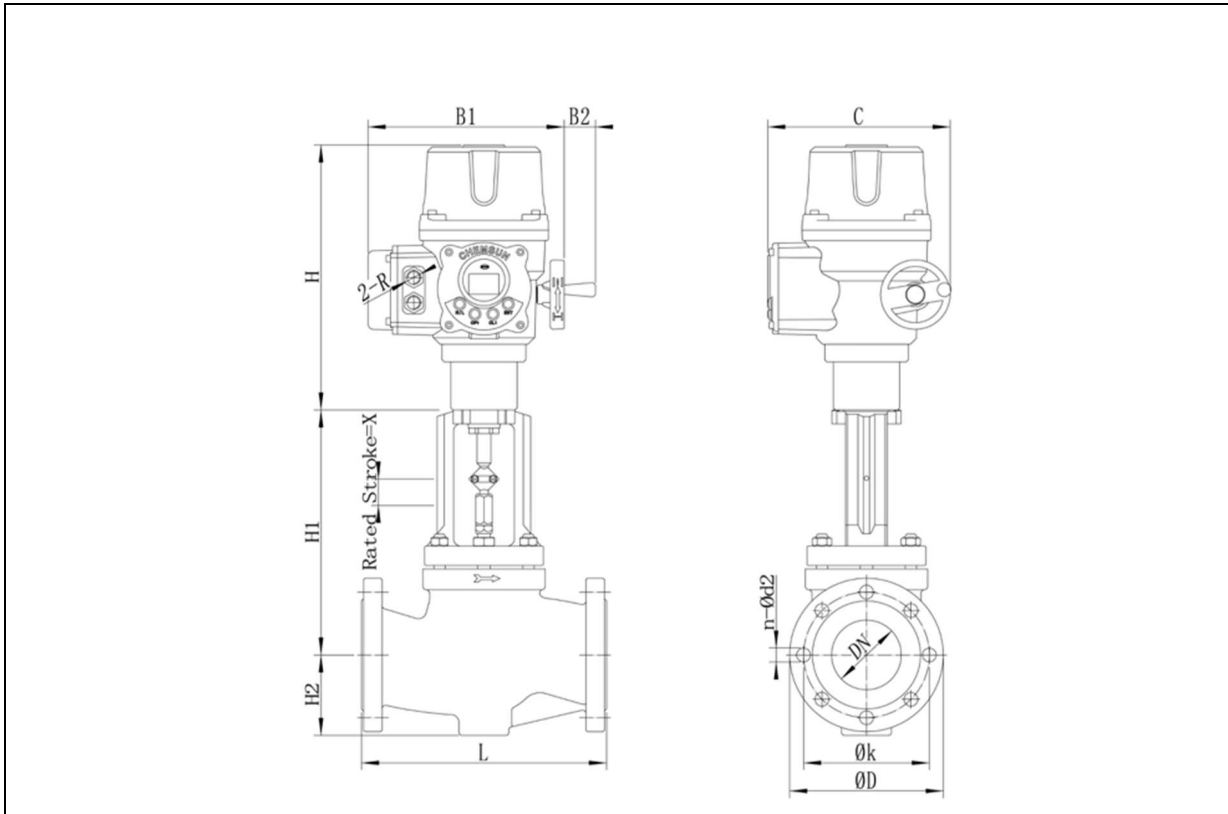

Main dimensions

Unit: mm

DN	L	H1		H2		B1	B2	H	C	R	X		
				C.S	F.S								
15	130	220		44	53	281	45	305	257	M20X1.5	15		
20	150				72							70	
25	160											92	
32	180			98									
40	200			98	—								
50	230	128											
65	290	260		—	—			315				430	60
80	310	360	380 ¹⁾		144								
100	350	390	415 ¹⁾		175								
125	400	—			235								
150	480				260								
200	600				480								
250	730												
300	850												

Note: According to DIN EN 1092 and DIN ISO 5211.

CHEMSUN E-Actuators CSR - G01 Series Rotary E-Actuator Selection type table

CHEMSUN E-Actuator	Type CSR- G01-	X	X	X	X	X	X	X	X	X	X	X
Rotary Stroke												
90° (≤95°)	1											
Milt-turn	2											
Special Angle (On request)	9											
Explosion-proof type												
ATEX, IEC Ex Exd IIC T6, IP67/68	1											
Non Ex, IP67	2											
Supply power												
24 V DC	1											
220 V AC	2											
110 V AC	3											
380 V AC	4											
24 V AC	5											
Special type (On request / Detailed instructions, when ordering)	9											
Input signal type												
4 – 20 mA	1											
0 – 10(5) V	2											
On/off switch (Dry contacts)	3											
Communication mode (Mod-Bus/M-Bus/NB/LOAR/4G/5G; Detailed instructions)	4											
Special type (On request / Detailed instructions, when ordering)	9											
Feedback signal type												
4 – 20 mA	1											
0 – 10(5) V	2											
On/off switch (Dry contacts)	3											
Communication mode (Mod-Bus/M-Bus/NB/LOAR/4G/5G; Detailed instructions)	4											
Special type (On request / Detailed instructions, when ordering)	9											
Power fail safe position												
FL (Fail Lock/Hold)	0											
FC (Fail Close)	1											
FO (Fail Open)	2											
FS (Fail Any Position)	3											
Max. Output torque. Nm (Gear Box A1/A1-S1/A1-S2/ A1-S3)												
NON	≤50	0										
A1	120	1										
A1-S1	220	2										
A1-S2	600	3										
A1-S3	1200	4										
Special	>1200 (On request / Recommend G03 Series)	9										
Number of alarm terminals												
NON (Standard)		0										
3 Groups (Standard)		3										
> 3 Groups (On request / Max. 6 Groups, and Detailed instructions are required when ordering.)		9										
The environment temperature												
Standard: -25 ~ +80℃		0										
Lower Temp.: -40 ~ +70℃		1										
Extrem-Low Temp.: -60 ~ +70℃		2										
Special Function												
Without		0										
HART; FF; PID loop; With temperature or pressure sensor; Flow characteristic compensation; With Mechanical Moment Switch, etc. (On request, Detailed instructions, when ordering)		9										

CHEMSUN E-Actuators CSL - G01 Series Linear E-Actuator Selection type table

CHEMSUN E-Actuator	Type CSL- G01-	X	X	X	X	X	X	X	X	X	X	X
Linear Stroke		↓										
20mm	1											
40mm	2											
65mm	3											
135mm	4											
Special Line (On request)	9	↓										
Explosion-proof type												
ATEX, IEC Ex Exd IICT6, IP67/68	1											
Non Ex , IP67	2	↓										
Supply power												
24 V DC	1											
220 V AC	2											
110 V AC	3											
380 V AC	4											
24 VAC	5											
Special type (On request / Detailed instructions, when ordering)	9	↓										
Input signal type												
4 – 20 mA	1											
0 – 10(5) V	2											
On/off switch (Dry contacts)	3											
Communication mode (Mod-Bus/M-Bus/NB/LOAR/4G/5G; Detailed instructions)	4											
Special type (On request / Detailed instructions, when ordering)	9	↓										
Feedback signal type												
4 – 20 mA	1											
0 – 10(5) V	2											
On/off switch (Dry contacts)	3											
Communication mode (Mod-Bus/M-Bus/NB/LOAR/4G/5G; Detailed instructions)	4											
Special type (On request / Detailed instructions, when ordering)	9	↓										
Power fail safe position												
FL (Fail Lock/Hold)	0											
FC (Fail Close)	1											
FO (Fail Open)	2											
FS (Fail Any Position)	3	↓										
Max. Output thrust. KN												
≤2.0	0											
5.0	1											
8.0	2											
12	3											
20	4											
30	5											
48	6											
>48 (On request)	9	↓										
Number of alarm terminals												
NON (Standard)	0											
3 Groups (Standard)	3											
> 3 Groups (On request / Max. 6 Groups, and Detailed instructions are required when ordering.)	9	↓										
The environment temperature												
Standard: -25 ~ +80℃	0											
Lower Temp.: -40 ~ +70℃	1											
Extrem-Low Temp.: -60 ~ +70℃	2	↓										
Special Function												
Without	0											
HART; FF; PID loop; With temperature or pressure sensor; Flow characteristic compensation; With Mechanical Moment Switch, etc	9	↓										

Output mechanical connection

The connection design conforms to ISO5211 international standard and is suitable for all kinds of mechanical connection to ensure reliable connection with all valves.

All electric actuators of chemsun are used in different assembly objects and have different terminal output modes. Special output terminal size can be provided according to the requirements of customers.

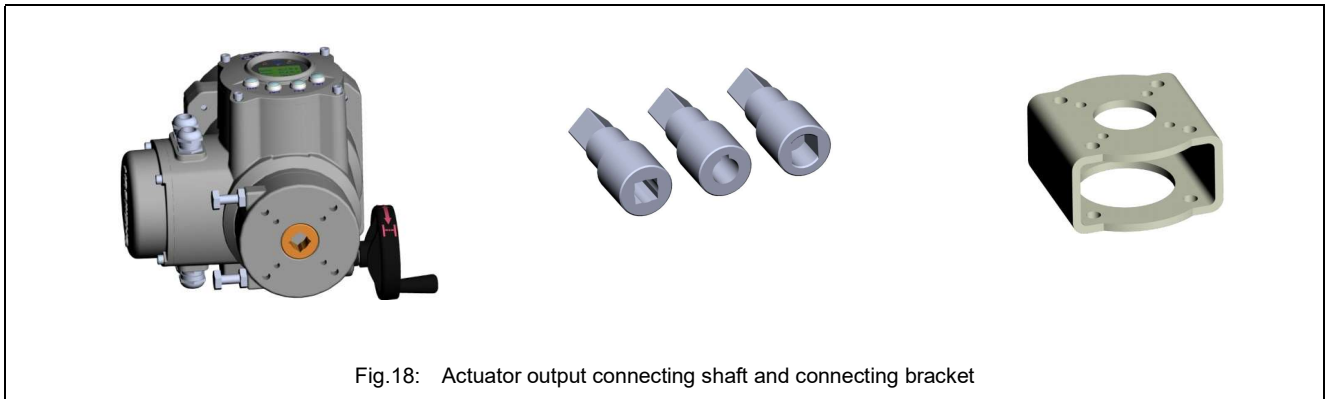

Ordering text 01

Rotary E-Actuator	Type CSR-G01- ...
Explosion-proof type	ATEX Exd IIC T5 / T6 ; Non Ex
Max. Torque	50-1200Nm, A1/A1-S1/A1-S2
Supply Power	24VDC ; 24/220/110/380VAC (50/60Hz)
Input / Output Signal	4-20mA ; 0 – 10(5)V; On-off Switch; Communication mode
Power Fail Safe Position	FL/FC/FO/FS
Valve Type	V-Ball Control Valve; Rotary-plug Valve; Butterfly Valve; O-Ball Valve ...

Ordering text 02

Linear E-Actuator	Type CSL-G01- ...
Explosion-proof type	ATEX Exd IIC T5 / T6 ; Non Ex
Max. Stroke	H=20,40,65,135 mm
Max. Thrust	2 – 48 KN
Supply Power	24VDC ; 24/220/110/380VAC (50/60Hz)
Input / Output Signal	4 -20mA ; 0 – 10(5)V ; On-off Switch; Communication mode
Power Fail Safe Position	FC/FO/FL/FS
Valve Type	Globe Valve; Knife Gate Valve; Gate Valve ...

*** Specifications subject to change without notice.



CHEMSUN EUROPE GMBH

Add: Schumannstraße 156, 63069 Offenbach am Main, Deutschland
Fon:+49(0)69 7598636 0 Fax:+49(0)69 7598636 88
URL: www.chemsun.de E-mail: sales@chemsun.de